EDK2612

USER MANUAL

FOR H8S/2612
ON-CHIP FLASH MICROCONTROLLER

Preface

Cautions

1. This document may be, wholly or partially, subject to change without notice.
2. All rights reserved. No one is permitted to reproduce or duplicate, in any form, a part or this entire document without Hitachi Micro Systems Europe Limited's written permission.

Trademarks

General

All brand or product names used in this manual are trademarks or registered trademarks of their respective companies or organisations.

Specific

Microsoft, MS and MS-DOS are registered trademarks and Windows and Windows NT are trademarks of Microsoft Corporation.

Document Information

Product Code: D003560_11

Version: 1.0

Date: 09/04/2002

Copyright © Hitachi Semiconductor America 2000-2002. All rights reserved.

Copyright © Hitachi Micro Systems Europe Ltd. 1995-2002. All rights reserved.

Copyright © Hitachi Europe Ltd. 1995-2002. All rights reserved.

Global: <http://www.hitachisemiconductor.com>

USA: <http://semiconductor.hitachi.com>

Europe: <http://www.hitachi-eu.com/semiconductors>

<http://www.hmse.com>

1. TABLE OF CONTENTS

1.	TABLE OF CONTENTS	3
2.	START-UP INSTRUCTIONS	4
2.1.	INSTALLING THE EVALUATION DEVELOPMENT KIT (EDK).....	4
2.2.	SERIAL CONNECTION	4
2.3.	POWER SUPPLY	4
3.	EDK BOARD LAYOUT	5
3.1.	EDK BLOCK DIAGRAM.....	5
4.	EDK OPERATION	6
4.1.	USER INTERFACE.....	6
4.2.	SERIAL INTERFACE.....	6
4.3.	SRAM.....	7
4.4.	MEMORY MAP	8
4.5.	LEDS.....	8
5.	BOARD OPTIONS	9
5.1.	JUMPER LINKS.....	9
5.2.	USER MODE SETTINGS – CJ5.....	10
5.3.	EDK OPTIONS – CJ4	10
5.4.	SERIAL PORT SELECTION.....	11
5.5.	FLASH PROGRAMMING HEADER	11
5.6.	BOOT CONTROL	12
6.	CODE DEVELOPMENT	13
6.1.	ADDITIONAL INFORMATION	13

2. START-UP INSTRUCTIONS

2.1. INSTALLING THE EVALUATION DEVELOPMENT KIT (EDK)

Please refer to the quick start guide provided for initial installation of the EDK.

A copy of the quick start guide and other information relating to this EDK at:

<http://www.hmse.com/products/edk/support/>

Installing the EDK requires power and serial connection to a host computer.

2.2. SERIAL CONNECTION

The serial communications cable for connecting the EDK to a host computer is supplied. The serial cable has 1:1 connectivity.

Figure 2-1 shows how to connect the EDK to a PC or notebook computer equipped with a nine pin D connector.

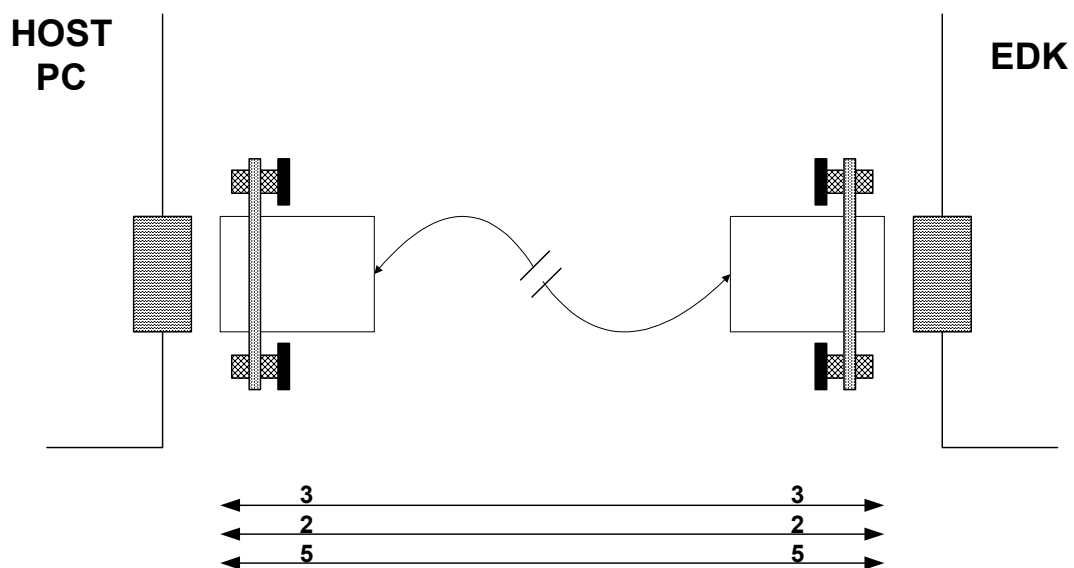

FIGURE 2-1: SERIAL CONNECTION TO PC/NOTEBOOK WITH DB-9 CONNECTOR (SUPPLIED)

2.3. POWER SUPPLY

The EDK hardware requires a power supply of +5V. Since total power consumption can vary widely due to external connections, port states, and memory configuration, use a power supply capable of providing at least 500mA at +5V DC \pm 5%.

The design is specified for evaluation of the microcontroller and so does not include circuitry for supply filtering/noise reduction, under voltage protection, over current protection or reversed polarity protection. Caution should be used when selecting and using a power supply.

The power connector on the EDK is a 2.5mm Barrel connector. The center pin is the positive connection.



FIGURE 2-2: POWER SUPPLY CONNECTION

Caution: Existing customers using E6000 products note that the polarity of this board is opposite to that for the E6000. Use of the E6000 power supply with this board will damage both board and power supply.

3. EDK BOARD LAYOUT

The diagram shows a general layout of the EDK board.

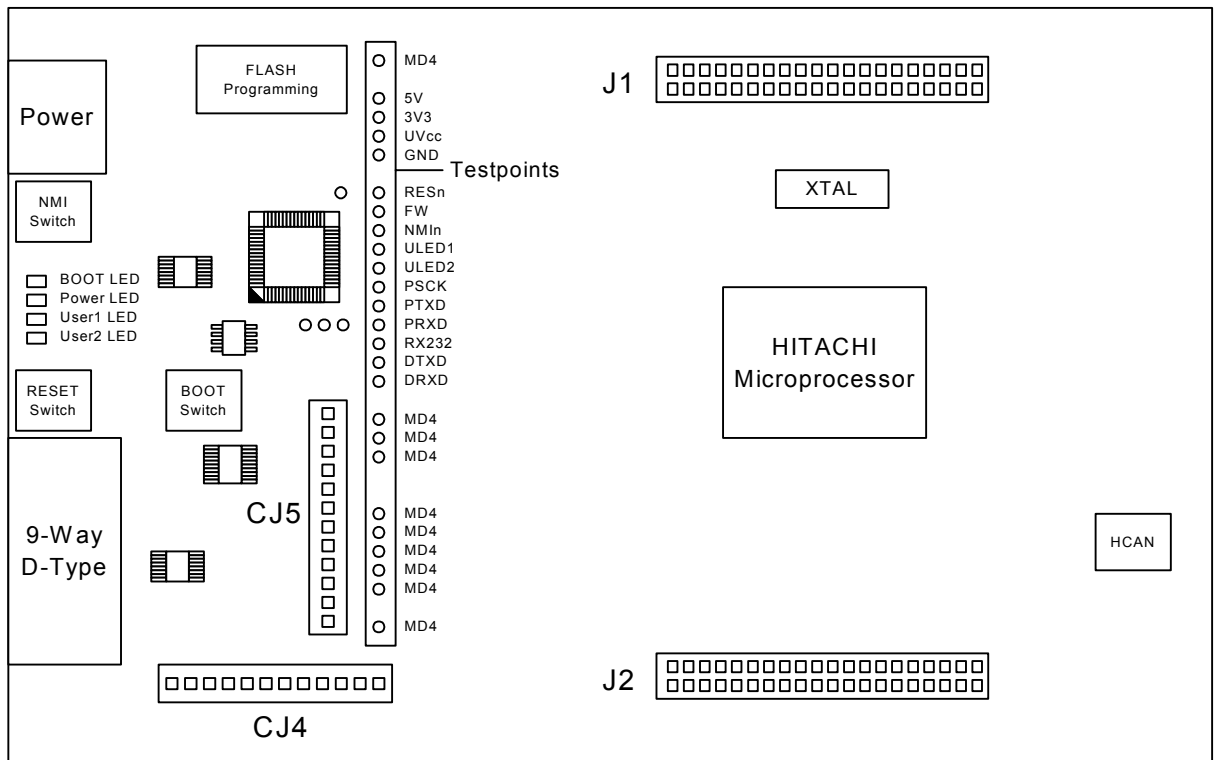

FIGURE 3-1: EDK BOARD LAYOUT

3.1. EDK BLOCK DIAGRAM

The diagram shows the connectivity of the components on the EDK board.

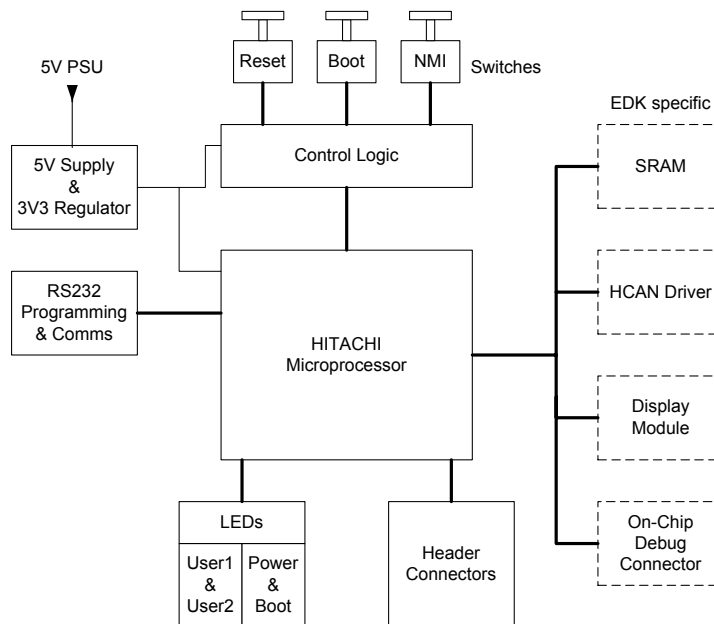

FIGURE 3-2: EDK BLOCK DIAGRAM

4. EDK OPERATION

4.1. USER INTERFACE

The EDK provides three buttons for influencing the operation of the board. The purpose of each button is clearly marked next to it. Refer to the board layout for positions (Section 3)

1. Reset Switch

This button provides the microcontroller with a timed reset pulse of at least 250mS.

2. Boot Switch

This button toggles the operating mode of the microcontroller. A complete description of this function is given in section 5.6.

3. NMI Switch

This button provides a de-bounced signal to the microcontroller for each operation of the button. There is no minimum or maximum activation time for this button.

4.2. SERIAL INTERFACE

The serial interface on the EDK board has several functions. The serial port on the microcontroller directly supports three wire serial interfaces. Options are provided on the board for the user to write handshaking routines using standard port pins. Other board option links allow users to control the entry and exit from boot mode using the same handshaking signals. Refer to section 5 for details on setting serial interface options.

4.2.1. CONNECTOR PIN DEFINITIONS

The EDK RS232 interface conforms to Data Communication Equipment (DCE) format allowing the use of 1-1 cables when connected to Data Terminal Equipment (DTE) such as an IBM PC. The cable used to connect to the EDK will affect the available board options. A fully wired cable can allow handshaking between the microcontroller and the host PC, subject to setting the board options and the availability of suitable host software. Handshaking is not supported as standard on the microcontroller so for normal use a minimal three-wire cable can be used. The minimum connections are unshaded in the following table.

EDK DB9 Connector Pin	Signal	Host DB9 Connector Pin
1	No Connection	1
2	EDK Tx Host Rx	2
3	EDK Rx Host Tx	3
4	No Connection	4
5	Ground	5
6	No Connection	6
7	* EDK CTS Host RTS	7
8	* EDK RTS Host CTS	8
9	No Connection	9

TABLE 4-1: RS232 INTERFACE CONNECTIONS

* These are not connected on the EDK by default. See section 5.4 for more details.

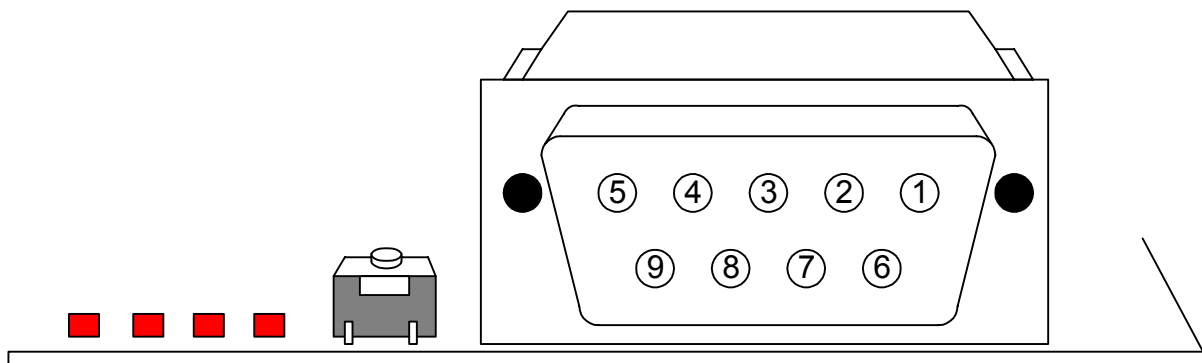

FIGURE 4-1: EDK SERIAL PORT PIN NUMBERING

4.2.2. CRYSTAL CHOICE

The operating crystal frequency has been chosen to support the fastest operation with the fastest serial operating speeds. The value of the crystal is 18.432MHz. The following table shows the baud rates and Baud Rate Register (BRR) setting required for each communication rate using the above default operating speed. It also confirms the resultant baud rate and the bit error rate that can be expected.

Baud Rate Register Settings for Serial Communication Rates												
SMR Setting:	0			1			2			3		
Comm. Baud	BRR setting	Actual Rate	ERR (%)	BRR setting	Actual Rate	ERR (%)	BRR setting	Actual Rate	ERR (%)	BRR setting	Actual Rate	ERR (%)
110	Invalid	Invalid	Invalid	Invalid	Invalid	Invalid	Invalid	Invalid	Invalid	81	110	-0.22
300	Invalid	Invalid	Invalid	Invalid	Invalid	Invalid	119	300	0.00	29	300	0.00
1200	Invalid	Invalid	Invalid	119	1200	0.00	29	1200	0.00	7	1125	-6.25
2400	239	2400	0.00	59	2400	0.00	14	2400	0.00	3	2250	-6.25
4800	119	4800	0.00	29	4800	0.00	7	4500	-6.25	1	4500	-6.25
9600	59	9600	0.00	14	9600	0.00	3	9000	-6.25	Invalid	Invalid	Invalid
19200	29	19200	0.00	7	18000	-6.25	1	18000	-6.25	Invalid	Invalid	Invalid
38400	14	38400	0.00	3	36000	-6.25	Invalid	Invalid	Invalid	Invalid	Invalid	Invalid
57600	9	57600	0.00	2	48000	-16.67	Invalid	Invalid	Invalid	Invalid	Invalid	Invalid
115200	4	115200	0.00	0	144000	25.00	Invalid	Invalid	Invalid	Invalid	Invalid	Invalid
230400*	2	192000	-16.67	Invalid	Invalid	Invalid	Invalid	Invalid	Invalid	Invalid	Invalid	Invalid
460800*	0	576000	25.00	Invalid	Invalid	Invalid	Invalid	Invalid	Invalid	Invalid	Invalid	Invalid

TABLE 4-2 CRYSTAL FREQUENCIES FOR RS232 COMMUNICATION

* Note: The device used to convert the RS232 serial information to logic signals for the microcontroller is limited to 120kBaud. The rates above this level can only be utilised if the user provides direct logic level communications.

The default communication rate for the EDK is indicated by the shaded selection.

The user may replace the HC49/U surface mounted AT cut crystal with another of similar type within the operating frequency of the microcontroller device. Please refer to the hardware manual for the microcontroller for the valid operating range.

Alternatively the user may fit an oscillator module – or provide an external clock source. When providing an oscillator module or external source it is highly recommended that the load capacitors for the AT crystal are removed from the PCB. These are physically placed within the PCB outline of the oscillator module for easy location and to ensure they are removed when using this option.

When changing the crystal frequency the pre-loaded debugging monitor will not function. In this situation the user is responsible for providing code to evaluate the device away from the default operating speed.

4.2.3. REMOVABLE COMPONENT INFORMATION.

This information is provided to allow the replacement of components removed from the board as described in section 4.2.2.

Component	Cct. Ref	Value	Rating	Manufacturer
Load Resistor	R8	1M Ω	0805 1%	Welwyn WCR Series
Load capacitors	C6,C7	12pF	0603 10% 25V	AVX 0603 3 A 150 KAT

TABLE 4-3: REMOVABLE COMPONENT INFORMATION

Care must be taken not to damage the tracking around these components. Only use soldering equipment designed for surface mount assembly and rework.

4.3. SRAM

This EDK does not support external address and data bus connections so there is no SRAM on this EDK.

4.4. MEMORY MAP

Table 4-4 illustrates the EDK memory map for mode 7.

Section End	Section Allocation
Section Start	
H' 00000000	Oh-Chip ROM
H' 01FFFF	
H' FFE000	On-chip RAM
H' FFEFBF	
H' FFF800	Internal I/O registers
H' FFF3F	
H' FFF60	Internal I/O registers
H' FFFBF	
H' FFFC0	On Chip RAM
H' FFFFF	

TABLE 4-4: MEMORY MAP (DEFAULT MODE 2)

4.5. LEDs

The EDK has four red LEDs. The function of each LED is clearly marked on the silk screen of the PCB. Please refer to the board layout diagram for position information (Section 3).

When the board is connected to a power source the Power (PWR) led will illuminate. The Boot mode indication LED will illuminate when the microcontroller has been placed into Boot mode. Please see section 0 for more details of this function.

There are two LEDs dedicated for user control these are marked USR1 and USR2. Each LED will illuminate when the port pin is in a logical high state.

The user LEDs are connected to the following ports:

LED Identifier	Port Pin	Microcontroller Pin	Pin Functions on Port Pin
USR1	P15	3	P15/PO13/TIOCB1/TCLKC
USR2	P16	4	P16/PO14/TIOCA2/nIRQ1

TABLE 4-5: LED PORT CONNECTIONS

5. BOARD OPTIONS

The EDK has a number of configuration settings set by jumpers CJ4 (A, B, C, D) CJ5 (A, B, C, D) and zero-ohm links. Common EDK functions can be set using the jumpers as described in sections 5.3 and 5.2. The additional zero-ohm links provide additional features that may be required to interface with other systems.

All the Jumper link settings are three pin options. There are four sets of options on each header.

The headers are numbered from 1 to 12 with pin 1 marked on the PCB by an arrow pointing to the pin. The diagram below shows the numbering of these jumper links and indicates jumpers fitted 1-2 for each three-pin jumper.

5.1. JUMPER LINKS

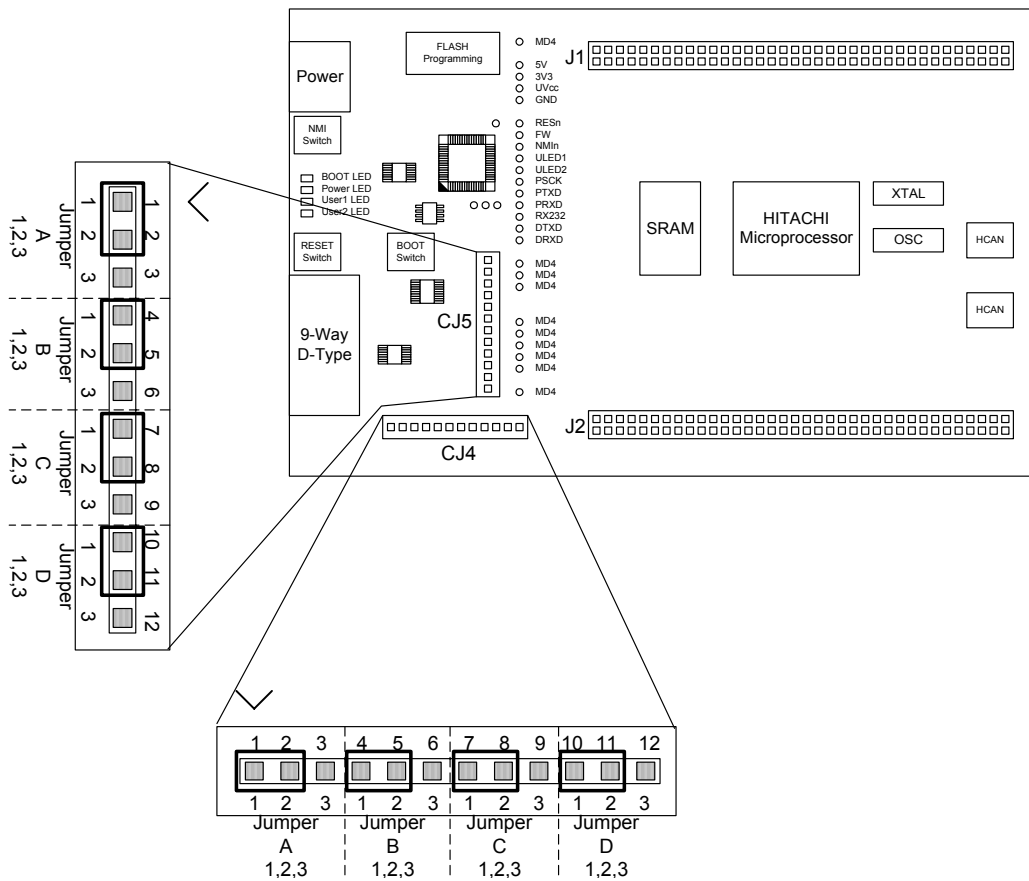

FIGURE 5-1: JUMPER CONFIGURATION

The following tables define each jumper and its settings.

5.2. USER MODE SETTINGS – CJ5

CJ5 is used to set the operating mode of the microcontroller.

These jumpers must be fitted at all times to ensure correct operation of the EDK.

Jumper	Function	Setting 1-2	Setting 2-3
CJ 5-A Default 2-3	User Mode Setting Bit 0	MD0 pulled High	MD0 pulled Low
CJ 5-B Default 1-2	User Mode Setting Bit 1	MD1 pulled High	MD1 pulled Low
CJ 5-C Default 2-3	User Mode Setting Bit 2	MD2 pulled High	MD2 pulled Low
CJ 5-D Default 1-2	User Mode Setting Bit 3	MD3 pulled High	MD3 pulled Low

TABLE 5-1: USER MODE: JUMPER SETTINGS (DEFAULT SETTINGS IN BOLD)

The default settings indicated in bold text place the microcontroller into Mode 7.

5.3. EDK OPTIONS – CJ4

The EDK options provide access to commonly used features of the EDK range.

These jumpers must be fitted at all times to ensure correct operation of the EDK.

Jumper	Function	Setting 1-2	Setting 2-3
CJ 4-A Default 2-3	Serial Receive Source	Disables the RS232 receive signal to enable the use of the Flash Programming Header	Enables the RS232 receive signal. The Flash Programming Header* must not be used in this state.
CJ 4-B Default 2-3	User Programming Mode	Disables the Flash write hardware protection. The flash can be overwritten in User Mode.	Enables the Flash write hardware protection. The flash can not be overwritten in User Mode.
CJ 4-C Default No Fit		No Function	
CJ 4-D Default No Fit		No Function	

TABLE 5-2: BOARD OPTION: JUMPER SETTINGS (DEFAULT SETTINGS IN BOLD)

*See section 5.5

The following table lists the connections to each jumper pin.

Pin	Net Name	Description
1	UVCC	Microcontroller Supply Voltage
2	RXDISn	Disable Flash Header functions. Pulled low. (Enables RX232)
3	No Connection	No Connection
4	UVCC	Microcontroller Supply Voltage
5	UPM	CPLD Controlled option to set Flash Write (FW). Pulled low.
6	No Connection	No Connection
7	No Connection	No Connection
8	No Connection	No Connection
9	No Connection	No Connection
10	No Connection	No Connection
11	No Connection	No Connection
12	No Connection	No Connection

5.4. SERIAL PORT SELECTION

The programming serial port is connected to the RS232 connector by default. This allows direct programming of the EDK using the supplied software tools. A secondary serial port is available on the microcontroller and can be connected to the RS232 connector by changing some board option links. The additional port option allows the user to write messages or connect to other devices via the serial port while programming support is provided by the Flash programming header.

The following surface mount, zero-ohm link settings are fitted by default and connect the RS232 header to the programming serial port of the microcontroller.

Zero-ohm Link ID	Default	Function	Microcontroller Port Pin
CR20	Fitted	Transmit data from EDK	PA1
CR23	Fitted	Receive data to EDK	PA2
CR19	Not Fitted	Alternate Transmit data from EDK	PC0
CR22	Not Fitted	Alternate Receive data to EDK	PC1

TABLE 5-3: OPTION LINKS – DEFAULT SETTINGS

To enable the use of this alternate port the user must change the settings to those in the following table.

Zero-ohm Link ID	Default	Function	Microcontroller Port Pin
CR20	Not Fitted	Transmit data from EDK	PA1
CR23	Not Fitted	Receive data to EDK	PA2
CR19	Fitted	Alternate Transmit data from EDK	PC0
CR22	Fitted	Alternate Receive data to EDK	PC1

TABLE 5-4: OPTION LINKS – ALTERNATE SERIAL PORT

The user may implement a handshaking protocol on the EDK. This is not supported with the software tools supplied. To support this option two spare port pins have been allocated on the microcontroller. Using these port pins the CTS and RTS lines of the host serial interface can be controlled.

The user may also control the operation of the board via the same handshaking lines. This is not supported with the software tools supplied but may be written by the user. Using the CTS line the user may simulate pressing the boot button, see section:5.6. This will cause the EDK to swap into and out of Boot mode on each low-level activation of CTS. Feedback of the current mode is provided on the RTS line. A high level indicates boot mode and a low level indicates user mode.

The following settings are made by default, and ensure that there are no conflicts on unnecessary microcontroller pins.

Zero-ohm Link ID	Default	Function	Microcontroller Port Pin
CR12	Not Fitted	Mode State out from EDK	N/A (From CPLD*)
CR7	Not Fitted	Change Mode request to EDK	N/A (From CPLD*)
CR16	Not Fitted	Alternate RTS232 – Ready to send – from EDK	PF4
CR13	Not Fitted	Alternate CTS232 – Clear to send – to EDK	PF0

TABLE 5-5: OPTION LINKS – SERIAL PORT CONTROL

* See section 5.6

Note: These setting pairs are exclusive:
 If CR12 and CR7 are fitted; CR16 and CR13 must not be fitted.
 If CR16 and CR13 are fitted; CR12 and CR7 must not be fitted.

5.5. FLASH PROGRAMMING HEADER

The Flash Programming header is used with the Hitachi Flash Debug Board (FDB). The FDB is a USB based programming tool for control and programming of Hitachi microcontrollers, available separately from Hitachi. This header provides direct access for the FDB to control the EDK microcontroller.

To utilise this header the user must make the following changes to the board configuration.

1. Disable the RX232 signal from the RS232 transceiver.
 Jumper link CJ4-A is provided for this purpose. Please refer to section 5.3.
2. Disable User Program Mode using jumper CJ4-B. Please refer to section 5.3.

Caution: Do not operate the board with the user mode jumpers removed and the FDB disconnected as the microcontroller mode pins will float to an indeterminate state. This may damage the microcontroller device.

5.6. BOOT CONTROL

The method for placing the microcontroller device in to Boot mode for reprogramming has been incorporated into a complex programmable logic device (CPLD). This is not necessary for most user designs but allows a measure of increased flexibility for the EDK designs. Mode transitions including boot mode transitions only require the reset to be held active while the mode settings are presented. On releasing reset the microcontroller will be in the required mode.

The logic design detects a power up event and provides a timed reset pulse to guarantee the reset of the device. At the end of the rest pulse the processor will be placed in user mode and any code in the device will execute.

During user mode the NMI button can be pressed at any time. This will provide a single de-bounced NMI interrupt to the device.

Pressing the boot button will cause the boot mode controller to reset the device and, during the reset period, present the required mode settings to start the device in boot mode. At the end of the reset period the boot mode settings will have been latched into the device which will then be ready to accept a boot mode connection via the RS232 interface or the flash programming header. Pressing the boot button during a normal reset will not cause the EDK to enter boot mode.

The boot mode settings are fixed at mode 3. The required mode settings are made using a tri-state capable buffer.

Note: The boot control device is programmed to support all possible EDK products.
For this reason the reset pulse is over 500ms. Repetitive activation of either the Boot or Reset buttons will restart the reset timer and extend the reset period. Pressing the boot button within the 500mS period of a reset will not cause the board to enter boot mode.

5.6.1. CPLD CODE

The code is based upon a four state machine providing a guaranteed reset period which can be extended by holding the relevant control input in the active state. When released the timer will extend the reset for approximately 500mS.

The states are split into two functions, one for User mode and one for Boot mode. The first state of each is used to hold the reset line active. When the timer expires then the second state is used to hold the device in the selected mode and wait for an external control signal to either move back into the user reset state or into the boot reset state.

5.6.2. STATE DIAGRAM

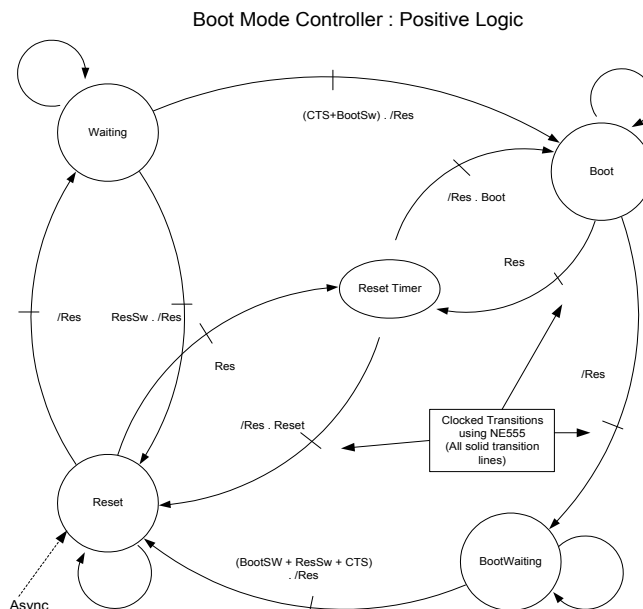

FIGURE 5-2: CPLD STATE DIAGRAM

6. CODE DEVELOPMENT

6.1. ADDITIONAL INFORMATION

For details on how to use Hitachi Embedded Workshop (HEW), with HDI-m, the EDK's resident debugger, refer to the HEW manual available on the CD or from the web site.

For information about the H8S series microcontrollers refer to the *H8S Series Hardware Manual*

For information about the H8S assembly language, refer to the *H8S Series Programming Manual*

Further information available for this product can be found on the HMSE web site at:

<http://www.hmse.com/products/edk/support/edk2612.htm>

General information on Hitachi Microcontrollers can be found at the following URLs.

Global: <http://www.hitachisemiconductor.com>

USA: <http://semiconductor.hitachi.com>

Europe: <http://www.hitachi-eu.com/semiconductors>

<http://www.hmse.com>